

Laundry Articulation Game

Phonemes: /k/, /g/, /f/, /v/



Breanna Allor, M.A., CCC-SLP

Instructions

- ✧ Print and laminate all materials.
- ✧ Have each student select a game board (pages 7-10).
- ✧ Cut out each card on pages 3-6 and put them in a bag/basket/bowl. Have the first student select a card and name the picture. He/she gets to keep the card if the word is articulated correctly. Have the student match the correct color shirts on his/her game board.
- ✧ The student must fill his/her complete game board to win!
- ✧ If the student draws a shirt color that is already matched on his/her board, the student must still name the picture correctly and can return the card back to the bag/basket/bowl for another player to select.

Note: Follow the instructions for the sock cards.

Gameplay is appropriate for up to four players.

Created by: Breanna Allor, M.A., CCC-SLP

Graphics: My Cute Graphics; Graphics Factory; Creative Clips





gift



ghost



goat



goose



gold



game



bag



flag



dog



bug

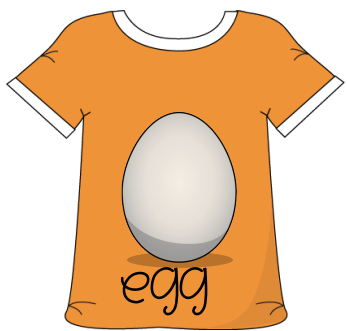

egg



frog



Put 1 card back.



Put 1 card back.

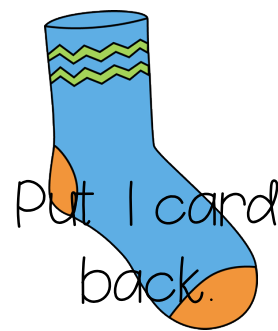

Put 1 card back.



Put 1 card back.



Put 1 card back.



Put 1 card back.

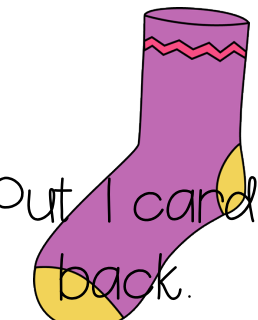

Put 1 card back.



Put 1 card back.

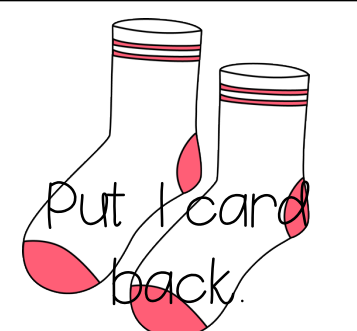
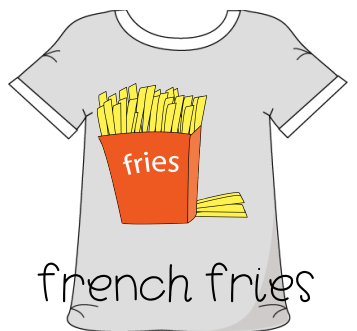



vase



van



volcano



veggies



vanilla



vest



five



olive



carve



love



glove



drive



Put 1 card
back.



Put 1 card
back.



Put 1 card
back.



Put 1 card
back.

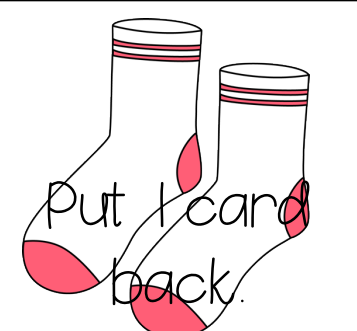

Put 1 card
back.



Put 1 card
back.



Put 1 card
back.



Put 1 card
back.

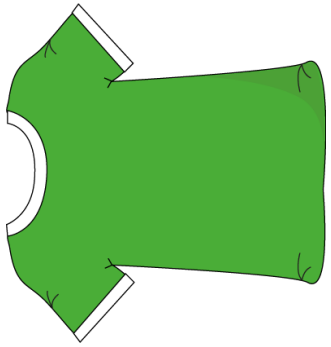

B. Allor, MA, CCC-SLP

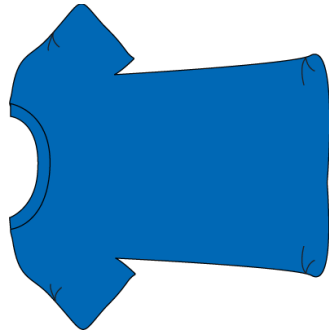

B. Allor, MA, CCC-SLP

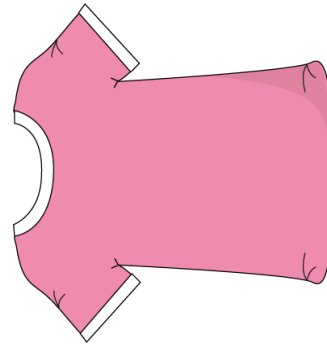

B. Allor, MA, CCC-SLP

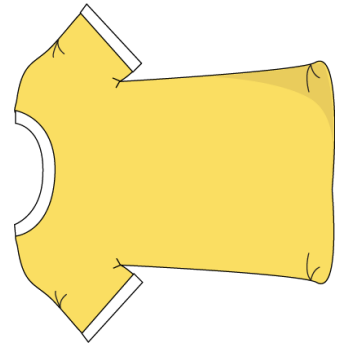

B. Allor, MA, CCC-SLP

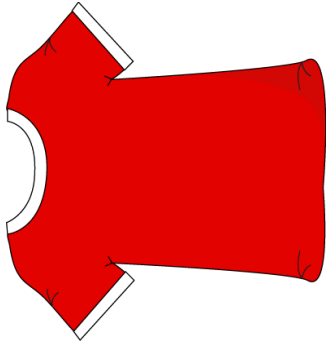

B. Allor, MA, CCC-SLP

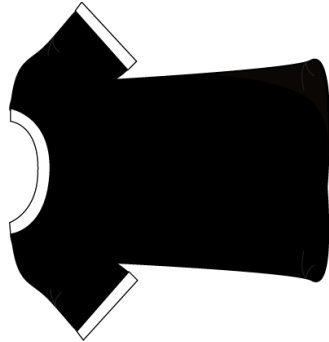

B. Allor, MA, CCC-SLP

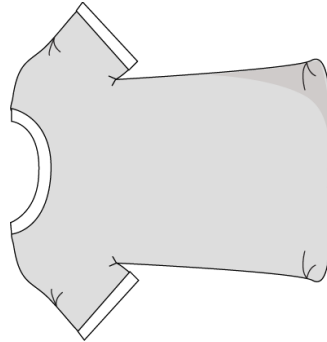

B. Allor, MA, CCC-SLP

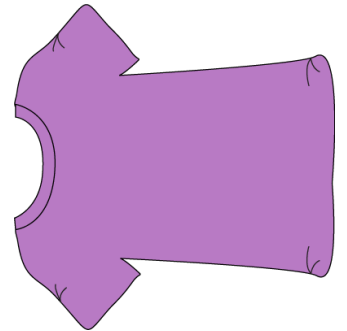

B. Allor, MA, CCC-SLP

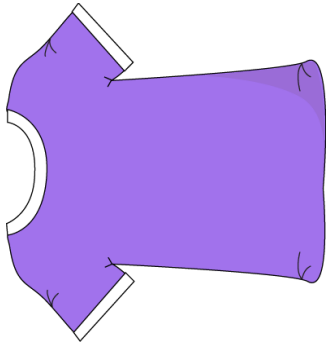

B. Allor, MA, CCC-SLP

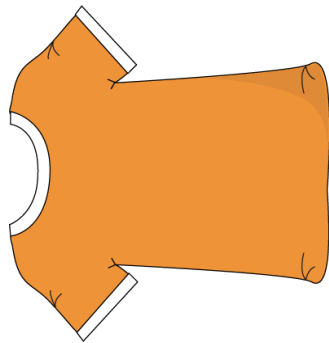

B. Allor, MA, CCC-SLP

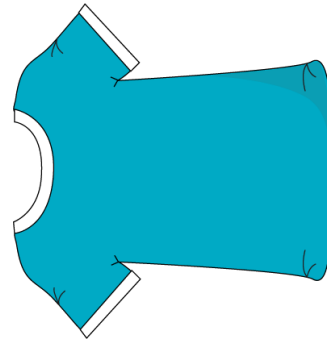

B. Allor, MA, CCC-SLP

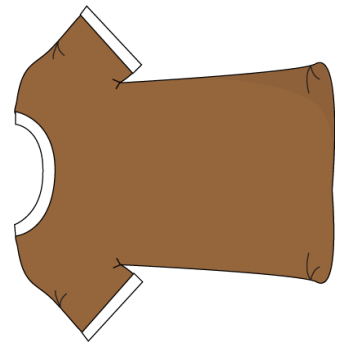

B. Allor, MA, CCC-SLP

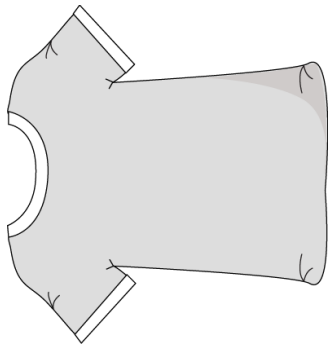

B. Allor, MA, CCC-SLP

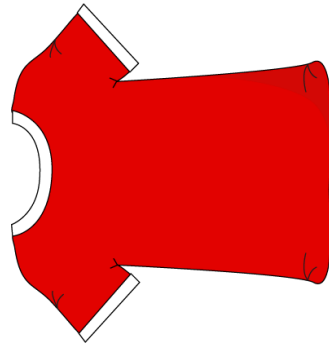

B. Allor, MA, CCC-SLP

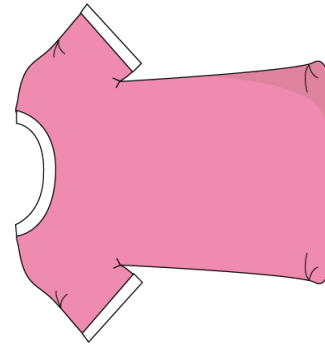

B. Allor, MA, CCC-SLP

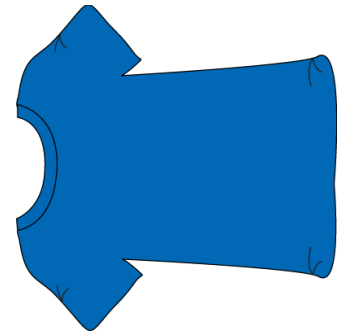

B. Allor, MA, CCC-SLP

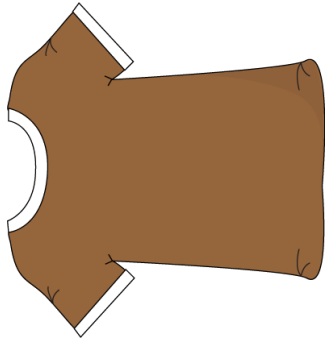

B. Allor, MA, CCC-SLP

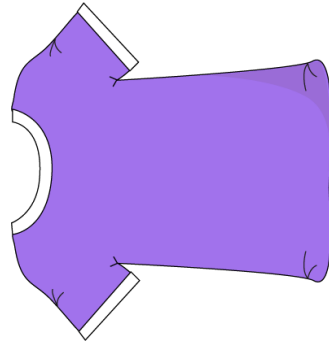

B. Allor, MA, CCC-SLP

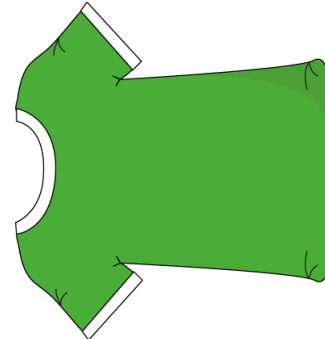

B. Allor, MA, CCC-SLP

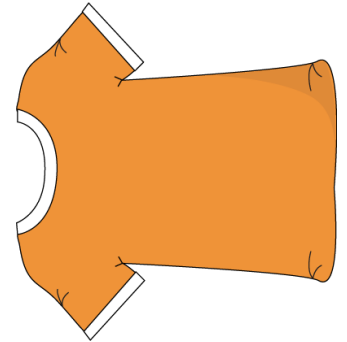

B. Allor, MA, CCC-SLP

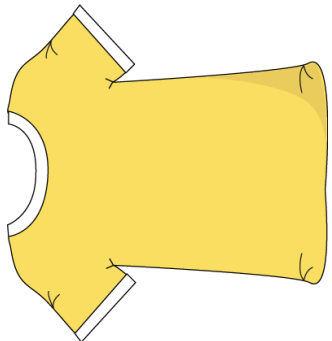

B. Allor, MA, CCC-SLP

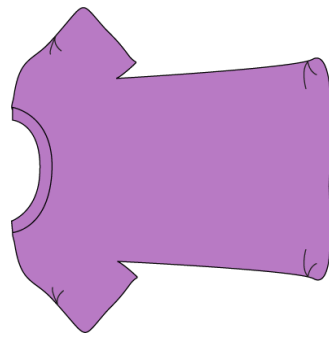

B. Allor, MA, CCC-SLP

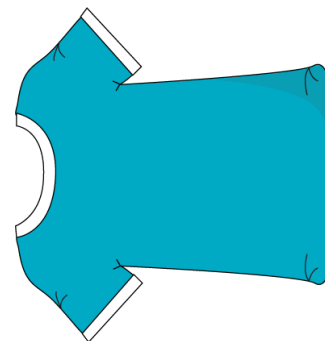

B. Allor, MA, CCC-SLP

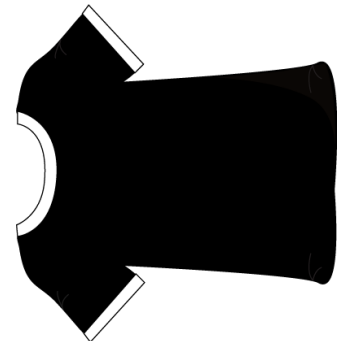

B. Allor, MA, CCC-SLP

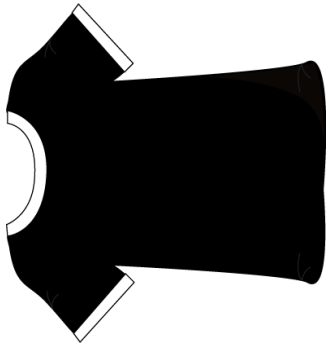

B. Allor, MA, CCC-SLP

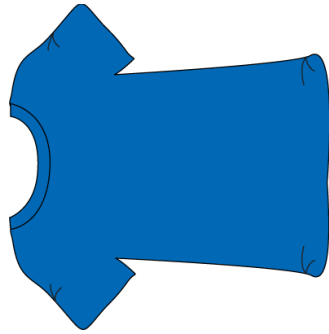

B. Allor, MA, CCC-SLP

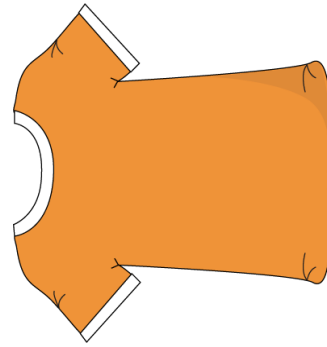

B. Allor, MA, CCC-SLP

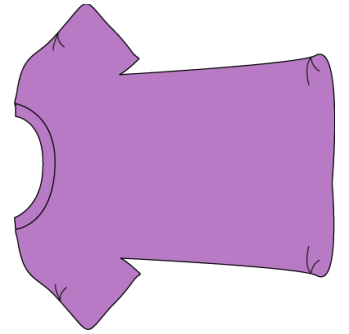

B. Allor, MA, CCC-SLP

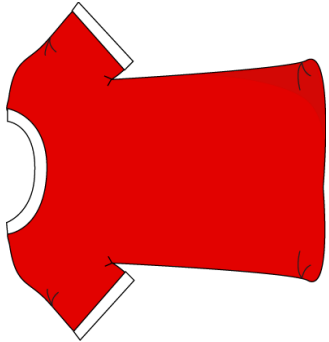

B. Allor, MA, CCC-SLP

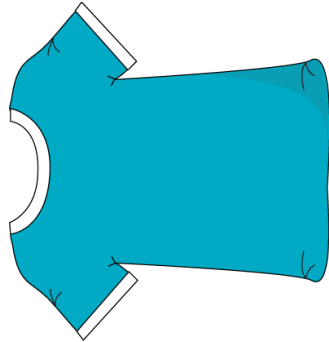

B. Allor, MA, CCC-SLP

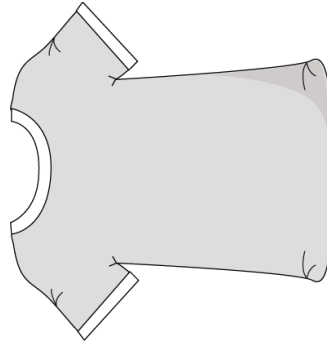

B. Allor, MA, CCC-SLP

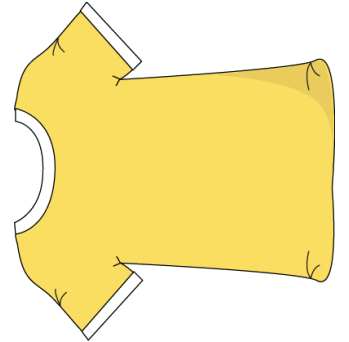

B. Allor, MA, CCC-SLP

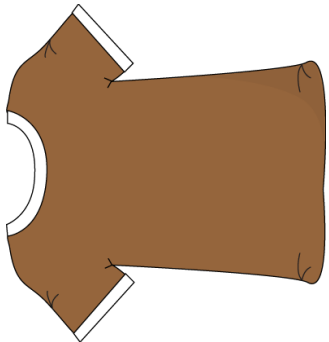

B. Allor, MA, CCC-SLP

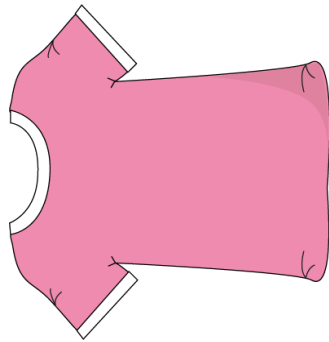

B. Allor, MA, CCC-SLP

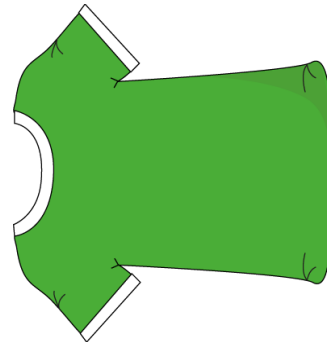

B. Allor, MA, CCC-SLP

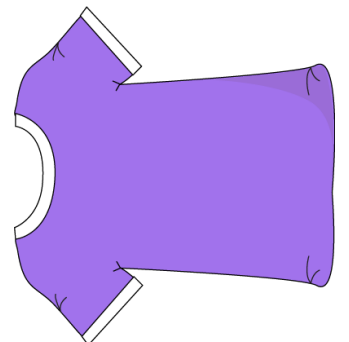

B. Allor, MA, CCC-SLP

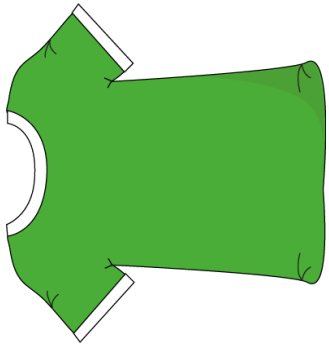

B. Allor, MA, CCC-SLP

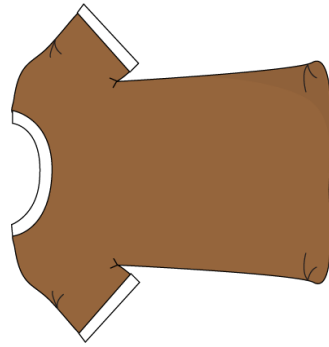

B. Allor, MA, CCC-SLP

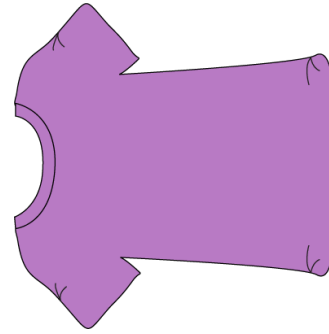

B. Allor, MA, CCC-SLP

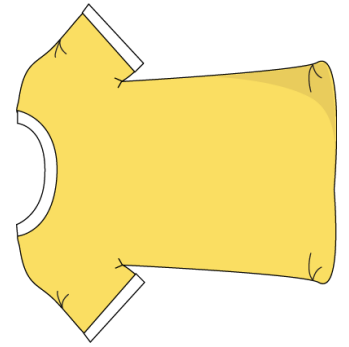

B. Allor, MA, CCC-SLP

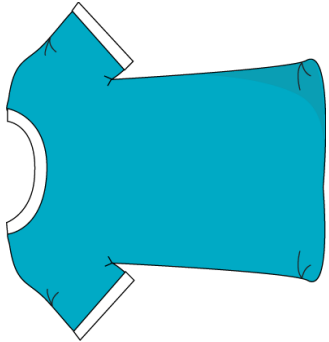

B. Allor, MA, CCC-SLP

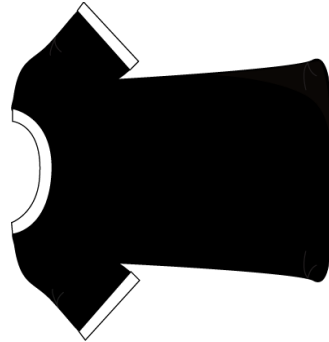

B. Allor, MA, CCC-SLP

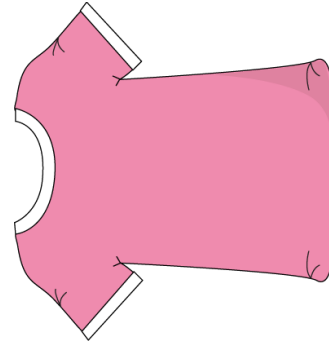

B. Allor, MA, CCC-SLP

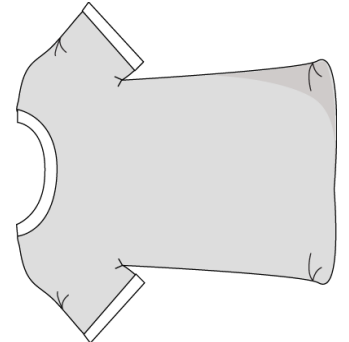

B. Allor, MA, CCC-SLP

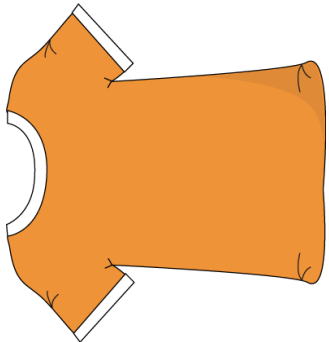

B. Allor, MA, CCC-SLP

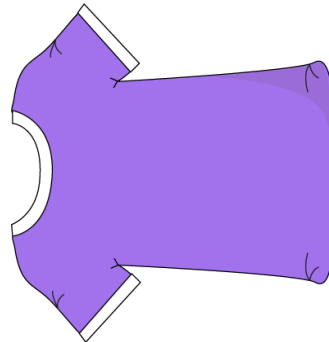

B. Allor, MA, CCC-SLP

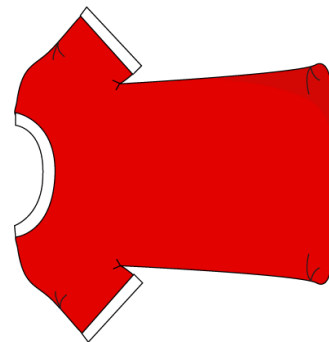

B. Allor, MA, CCC-SLP

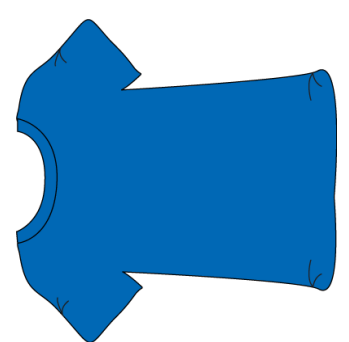

B. Allor, MA, CCC-SLP

Thank you for your purchase!



Breanna

Don't forget to leave feedback on TpT. Leaving feedback allows you to earn credits for money off of future purchases!



Thank you for purchasing my product. I sincerely hope it meets the needs of your students.

Terms of Use:

All rights to this product are reserved to the author and remain the intellectual property of the author Breanna Allor, M.A., CCC-SLP.

Purchase of this item entitles you to print and reproduce the pages in limited quantities for single classroom use only. Duplication for others or commercial use is strictly prohibited. Please purchase multiple licenses if you desire to share this product with fellow professionals or parents.

Copying any part of this product and placing it on the internet without specific written consent from the author is forbidden and is a violation of the Digital Millennium Copyright Act (DMCA).

Questions, concerns, and comments can be submitted to breannaallor@gmail.com

Visit Breanna's Speech Blog for more activities and for a peek into my speech room.
<http://www.breannasspeechblog.com>

Please follow my TpT store for more products.
<http://www.teacherspayteachers.com/Store/Breanna-Allor>

Follow me on Pinterest.
<http://www.pinterest.com/breannaallor/>

Follow me on Facebook.
<http://www.facebook.com/breannasspeechshop>

Follow me on Instagram.
http://www.instagram.com/breanna_allor/